

**ACME CO**  
**SALES PRESENTATION AND FORECAST**  
• Sales Training Video  
• Annual Corporate Forecast  
Prepared for: John L. Smith,  
VP of Sales and Marketing

**ON-DEMAND  
DIGITAL PUBLISHING™**

PRODUCER III

  
RIMAGE™

Hospitals  
and imaging centers  
trust Rimage disc publishing  
systems to deliver potentially  
life-saving patient  
information

Medical Imaging Ltd

**MI**

Patient: John Smith

ID:6549843WE4

Date: 0805

Scan: MRI Frontal Lobe



Rimage disc  
publishing solutions are  
behind the scenes in the  
most demanding on-demand  
photo, music, business  
service and video retail  
environments



Introducing Producer III :  
The all-in-one solution for  
on-demand disc publishing.



*Managing, archiving and distributing the expanding volume of digital content generated every day is a challenge for any size organization. But it also presents a unique opportunity to improve the workflow of digital content and management of information.*

On-demand digital publishing™ from Rimage offers a cost-effective and efficient solution to the continuously growing need for secure archiving and distribution of critical data such as video demonstrations, product parts and price lists, corporate reports, engineering drawings and software versions to name a few. Now one solution enables your entire organization to publish customized digital content and high-quality discs automatically, on-demand, as needed.

### **The most powerful and flexible “plug and play” system available.**

Connect a Producer III to your network and your entire organization has instant desktop access to a complete disc publishing solution. One disc or a hundred, CD, DVD or BD, full color indelible Everest™ or fast monochrome PrismPlus!™ printing technology — Producer III combines high-speed recording, professional direct-to-disc printing and powerful workflow and production capabilities for unmatched performance and ease of use.

Designed for the most demanding production environments in the world, Producer III can be configured for a wide range of applications. Using the power of Rimage's Application Programming Interface (API), Producer systems can be configured as network devices available to anyone in your company. They can quickly plug into any workflow environment and integrate with any existing application. Whenever you demand publishing performance, Producer III is ready and available.

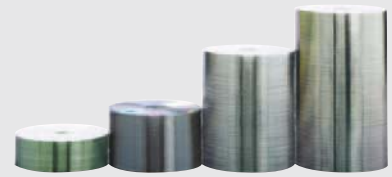

**Unmatched speed.** Optimized for the fastest throughput available, **Producer III** combines **exclusive Adaptive Streaming™** technology, **accelerated caching**, **high-speed recorders** and the **industry's most robust robotics**. You can **automatically record and print up to 100 unique discs per hour.\***

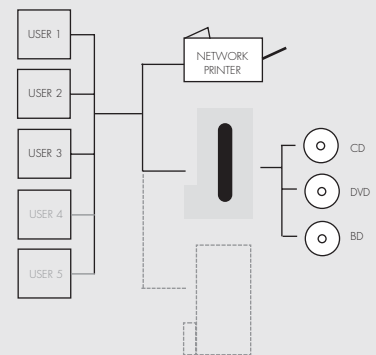

**Network-ready flexibility.** **Connect a Producer III to your network and you're ready for high-volume, high-quality digital publishing.** **Producer III can be configured for expanded capacity with the flexibility to seamlessly switch between CD, DVD and BD publishing runs.** **For increased production volume, you can easily add more systems.**

\* Depending on data format, content and printing options.

### Quantity, quality, customization and control.

Producer III does it all. Simply provide CD/DVD/BD publishing or duplication content and labeling information through the intuitive screen prompts, and Producer III takes care of everything in one complete process. It's as easy to use as a network printer.

Whether you are recording and printing for internal or external purposes – your image matters. You can count on your image being conveyed to your stakeholders clearly and concisely using Rimage's thermal printers - the fastest and best quality printers on the market. From virtually indestructible full-color labels, to quick, one-off monochromatic titles, the Quick Disc wizard-based software provides step-by-step custom disc creation. Disc printing uniformity throughout the company can be hard to manage; the Rimage software allows you to load in pre-designed templates for consistent branding and messaging. Best of all, you control everything from the convenience of your desktop.

Need five discs now and five hundred tomorrow? Customizing production runs is easy. Check CD/DVD/BD job progress with at-a-glance system monitoring including time to job completion, project consumable tracking and job queue status. Users are only prompted as needed or notified via email when their run is completed. On-demand disc publishing doesn't get any easier — or more efficient.

### Run with the leader in reliability.

Take a close look inside a Producer III and you'll see it's built for the long run. From Rimage designed robotics to cutting edge printing solutions, Producer III brings together industry-leading technology and nearly three decades of pioneering Rimage disc publishing innovations. Nothing on the market today meets Producer III's performance, versatility or reliability standards.

Whether it's one disc or tens of thousands, leading organizations worldwide depend on Rimage solutions to confidently publish critical digital content. The more data your organization generates, the more you need a Producer III.

*Rimage Everest thermal retransfer printing technology offers the only truly permanent direct-to-disc, high resolution printing solution.*



### Printing versatility and permanence

**Choose from the industry's fastest and most economical quality printing technologies — PrismPlus™ for fast monochrome printing, and Everest™ for indelible, full-color labels. For critical labeling needs, Everest permanently bonds high-resolution printing directly to each disc for a waterproof and virtually indestructible surface.**

*Rimage PrismPlus! thermal printing is the fastest and most affordable method of direct-to-disc printing.*





**Save time and money.** With network-wide access, on-demand publishing can help improve workflow and data distribution, eliminate unnecessary inventory and reduce the time and cost of outsourcing. Plus, you can create entirely new revenue streams publishing customized content on-demand.



*High-performance robotics assure "hands-off" reliability disc after disc.*

**Complete control.** Rimage designed QuickDisc™ software makes job creation and workflow management a snap. The powerful, wizard-based software provides step-by-step disc label design, or you can load in your own templates. With desktop or remote access, you get at-a-glance system status, job progress and prompts as needed — with e-mail notification when your production run is complete.

## Guaranteed performance backed by worldwide support.

Rimage software, hardware, discs and consumables are perfectly matched for consistent performance, guaranteed data integrity and superior print quality. Convenient Rimage Media Kits are prepackaged in a range of quantities with matched print ribbons and discs for guaranteed performance and world-wide data accessibility.

Whatever your publishing application, you can count on Rimage for a full range of support and maintenance options. Choose from three levels of Customer Care Services - Software Care, Exchange Care and On-Site Care.

From online upgrades and diagnostics to same day component and system shipping, we're here to help keep you up and running 24/7.



**Producer III : 7000 Series**

Disc Capacity: 300 disc capacity with four 100-disc bins configurable to input, output, or reject of any supported disc type.  
Power: 100-240VAC, 4.7-3.7A, 60/50 Hz, 500W maximum  
Certifications: Emission: FCC Class B  
Safety: UL, cUL, CE  
Operating Temperature: 60°F - 86°F (15.5°C - 30°C)  
Relative Humidity: 40% - 80%  
Number of Disc Drives: 2

### Producer III Networked Attached Model

Embedded computer  
Network Connection: Gigabit Ethernet  
Physical Size: H 24.625" X W 15.5" (16.1" door) X D 24.75" (62.5cm X 39.4cm (40.9 door) X 62.9cm)  
Weight: Loader 97lb (44kg) Everest 50lb (22.7kg) Prism 23lb (10.5kg)

### Producer III Standard Model

Physical Size: H 24.625" X W 15.5" (16.1" door) X D 24.75" (62.5cm X 39.4cm (40.9 door) X 62.9cm)  
Interface: FireWire™ 800 to recorders, USB to Printer/Robotics  
Weight: Loader 75lb (34kg) Everest 50lb (22.7kg) Prism 23lb (10.5kg)



**Producer III : 8000 Series**

Disc Capacity: 300 disc capacity with four 100-disc bins configurable to input, output, or reject of any supported disc type.  
Power: 100-240VAC, 4.7-3.7A, 60/50 Hz, 500W maximum  
Certifications: Emission: FCC Class B  
Safety: UL, cUL, CE  
Operating Temperature: 60°F - 86°F (15.5°C - 30°C)  
Relative Humidity: 40% - 80%  
Number of Disc Drives: 4  
External Output Bin

### Producer III Networked Attached Model

Embedded computer  
Network Connection: Gigabit Ethernet  
Physical Size: H 28.125" X W 15.5" (16.1" door) X D 24.75" (71.4cm X 39.4cm (40.9 door) X 62.9cm)  
Weight: Loader 110lb (50kg) Everest 50lb (22.7kg) Prism 23lb (10.5kg)

### Producer III Standard Model

Physical Size: H 28.125" X W 15.5" (16.1" door) X D 24.75" (71.4cm X 39.4cm (40.9 door) X 62.9cm)  
Interface: FireWire™ 800 to recorders, USB to Printer/Robotics  
Weight: Loader 88lb (40kg) Everest 50lb (22.7kg) Prism 23lb (10.5kg)

#### Rimage Corporation

7725 Washington Avenue South  
Minneapolis, Minnesota 55439 USA  
Toll Free: 800.445.8288  
Tel: 952.944.8144  
Fax: 952.944.7808  
www.rimage.com

#### Rimage Europe

Rimage Europe GmbH  
Albert-Einstein-Strasse 26  
63128 Dietzenbach, Germany  
Tel: (49) (0) 6074 8521 0  
Fax: (49) (0) 6074 8521 100  
www.rimage.de

#### Rimage Asia/Pacific

Rimage Japan Co., Ltd.  
3-15 Kanda Nishikicho Chiyoda-Ku  
Tokyo 101-0054 Japan  
Tel: +81.3.5238.8465  
Fax: + 81.3.5238.8463  
www.rimage.co.jp

